

Model	CLG2R016/20-SM/N
Drive	Electric
Operator type	Seated
Load capacity	1600 / 2000kg

CLG2R016/20-SM/N REACH TRUCK



SAFE AND RELIABLE

THE TILTING OF THE FORK

The tilting of the fork can effectively improve the stability of the whole vehicle and the loading capacity at height.

THE ELECTRO-HYDRAULIC PROPORTIONAL CONTROL SYSTEM

The electro-hydraulic proportional control system has good fretting performance, more stable work and more precise control.

SPEED LIMIT FUNCTION

Speed limit function, when the forklift lifts to a certain height, the driving speed of the forklift will automatically decrease to ensure the safety of high position operation.

THE HEIGHT LIMIT FUNCTION

The height limit function, the lifting motor will automatically power off to ensure the safety of lifting when the forks lift to the maximum height.

TURNING SPEED LIMIT CONTROL

Turning speed limit control prevents the truck from tipping sideways when turning, ensuring the safety of the truck when turning.



SMOOTH DECELERATION

Smooth deceleration when the mast reaches/ backwards to the end can ensure the stability of the mast movement.

MOTOR TEMPERATURE DETECTION AND CONTROL FUNCTION

The motor temperature detection and control can effectively prevent the motor from being damaged due to excessive temperature.

The motor current detection and control can effectively prevent the motor from being damaged due to excessive current.

ENERGY EFFICIENT:

High-speed lifting and lowering control improves your work efficiency.

It adopts AC drive motor, hydraulic pump motor and steering motor, with long service life, maintenance-free and reliable performance.

Regenerative braking to achieve energy recovery and extend battery life.

All lights use LED, durable and energy-saving.

RELIABLE BRAKING

The combination of electromagnetic brake and hydraulic brake has a short braking distance, no deviation, no impact, and is safe and reliable.

ONE-KEY START OPERATION FUNCTION

The parking electromagnetic brake can realize the one-key start operation function no matter it is on the slope or on the smooth ground.

CAN BUS

Using CAN bus communication technology, electrical wiring is simple, the compatibility is good, and the reliability is high.

AC FREQUENCY CONVERSION SPEED CONTROL TECHNOLOGY

AC frequency conversion speed control technology enables stepless closed-loop speed control of driving, lifting, and steering drives, which is accurate and reliable.



ROBUST DESIGN & EXCELLENTS TABLITY

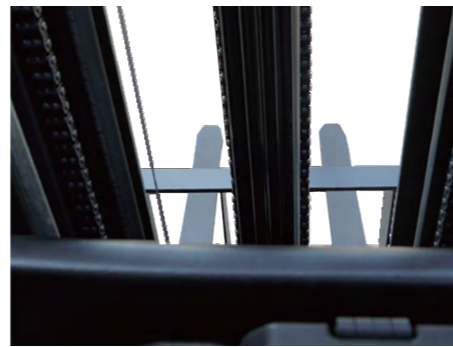
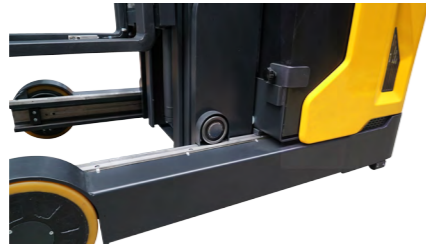
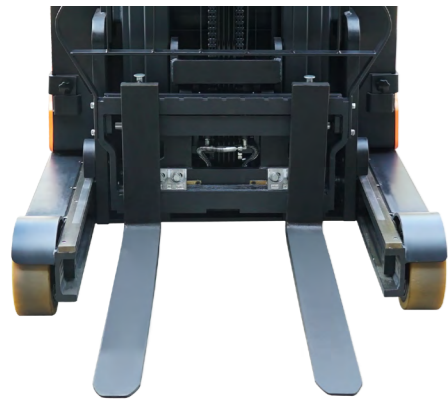

EXCELLENT STABILITY

The powerful chassis structure and reasonable center of mass distribution make the forklift have excellent stability.

MASTS FORWARD MORE STABLE.

The high-precision forward sliding rail and excellent clearance compensation design make the forward movement of the masts more stable.

GOOD VISION

The reasonable layout of the lifting cylinder and pipeline system, the mast pipeline is simple and beautiful, and the vision is good.

COMFORTABLE DRIVING AND EASY OPERATION



LOW-NOISE

Low-noise gear hydraulic pump reduces the lifting noise of the whole vehicle. Travel motor controllers, hydraulic pump motor controllers and steering motor controllers of international well-known brands are self-protected, maintenance-free, and have superior performance.

DRIVING SPACE

The spacious driving space and ergonomic layout reflect the humanized design of the vehicle.

SHOCK-ABSORBING SEAT

Shock-absorbing seat, adjustable backrest, and seat belt as standard.

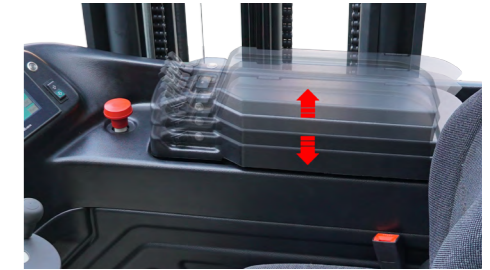
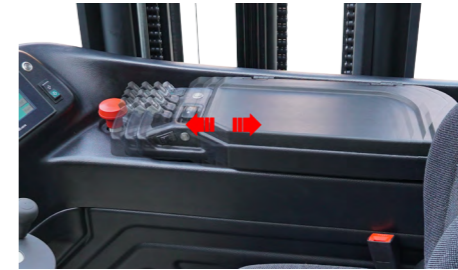

BEST OPERATING EXPENIENCN

The steering wheel and central control console can be adjusted freely in all directions to suit your best operating habits.



FINGERTIP OPERATION

Centralized control console, fingertip operation, convenient and accurate.



LCD INSTRUMENT

Multi-function color LCD instrument can display information such as steering wheel position, battery power, power alarm, fault code, running time, driving speed etc. The driving speeds of low, medium and high third gear can be set through the meter.



180 ° / 360 ° STEERING

Adopting AC EPS electronic power steering system, the steering is light and has automatic centering function, and the 180 ° / 360 ° steering mode can be switched in real time.



In order to replace the battery its tray should be reached forw ards. The mechanism for battery's tray release is located near with operator's foot.



SPECIFICATIONS

IDENTIFICATION					
Model		CLG2R016-SM/N		CLG2R020-SM/N	
Drive		Electric		Electric	
Operator type		Seated		Seated	
Load capacity / rated load	Q (kg)	1600		2000	
Load centre	c (mm)	600		600	
Load distance, centre of support arm wheel to face of forks	x (mm)	365/176		395/200	
Wheelbase	y (mm)	1400		1500	
WEIGHTS					
Service weight including battery	kg	3960	4220	3990	4250
Axle load, mast retracted without load, drive/support arm wheel	kg	2420/1540	2560/1660	2450/1540	2580/1670
Axle load, mast extended with load, drive/support arm wheel	kg	830/4760	746/5474	890/4700	766/5484
Axle load, mast retracted with load, drive/support arm wheel	kg	2100/3460	2270/3950	2180/3410	2290/3960
WHEELS					
Drive/support arm wheel		PU		PU	
Wheel size, front	xw (mm)	343X140		343X140	
Wheel size, rear	xw (mm)	285X110		330X110	
Wheels, number front/rear (x=driven wheels)		1x/2		1x/2	
Track width, rear	b11 (mm)	1160		1160	
DIMENSIONS					
Tilt of fork, forward/backward	°	4°/-2°		4°/-2°	
Height, mast extended	h1 (mm)	3900		3900	
Free lift	h2 (mm)	3290		3290	
Lift height	h3 (mm)	9500		9500	
Extended mast height	h4 (mm)	10410		10410	
Height of overhead guard (cab)	h6 (mm)	2200		2200	
Seat height	h7 (mm)	960		960	
Height of support arms	h8 (mm)	270		270	
Height of lowered forks	h13 (mm)	40		40	
Overall length	l1 (mm)	2412		2488	
Length to face of forks	l2 (mm)	1262		1338	
Overall width	b1 (mm)	1270		1270	
Fork dimensions	s/e/l (mm)	40/100/1150		40/120/1150	
Fork carriage ISO 2328, class/type A, B		2/A		2/A	
Width across forks	b5 (mm)	220/750		240/750	
Distance between support arms	b4 (mm)	900		900	
Reach distance	l4 (mm)	525		529	
Ground clearance, with load, below mast	m1 (mm)	90		90	
Ground clearance, centre of wheelbase	m2 (mm)	75		75	
Aisle width for pallets 1000 x 1200 crossways	Ast(mm)	2720		2840	
Aisle width for pallets 800 x 1200 lengthways	Ast(mm)	2780		2900	
Turning radius	Wa (mm)	1650		1750	
Length across support arms	l7 (mm)	1780		1900	
PERFORMANCE DATA					
Travel speed, with/without load	km/h	10.5/10.5	10.5/10.5	10.5/10.5	10.5/10.5
Lift speed, with/without load	m/s	0.35/0.5	0.25/0.5	0.35/0.5	0.25/0.5
Lowering speed, with/without load	m/s	0.45/0.45	0.45/0.45	0.45/0.45	0.45/0.45
Reach speed, with/without load	m/s	0.1/0.1	0.1/0.1	0.1/0.1	0.1/0.1
Max. gradeability, with/without load	%	10/10	10/10	10/10	10/10
Service brake		Hydraulic/electric		Hydraulic/electric	

ELECTRIC MOTOR					
Drive motor rating S2 60 min	kW	6.4	7	6.4	7
Lift motor rating S3 15%	kW	12.5	8.2	12.5	12
Battery voltage, nominal capacity K5	V/Ah	48/420, 560, 700	48/420, 560, 700	48/560, 420, 700	48/560, 420, 700
Battery weight	kg	750	750	950	950

OTHER					
Type of drive control		AC		AC	
Valve control type		electromagnetic valve	Mechanical valve	electromagnetic valve	Mechanical valve
Sound level at the driver's ear according to EN 12 053	dB(A)	68		68	

Model	Lift height h3 (mm)	Free lift h2 (mm)	Mast height h1 (mm)	Load capacity kg	Tilt of fork °
16M450	4500	1563	2235	1600	4°/-2°
16M500	5000	1730	2400	1600	4°/-2°
16M550	5500	1897	2568	1600	4°/-2°
16M600	6000	2063	2735	1600	4°/-2°
16M650	6500	2230	2900	1500	4°/-2°
16M700	7000	2397	3068	1400	4°/-2°
16M750	7500	2563	3234	1200	4°/-2°
16M800	8000	2730	3400	1000	4°/-2°
16M850	8500	2897	3567	900	4°/-2°
16M900	9000	3063	3734	800	4°/-2°
16M950	9500	3230	3900	600	4°/-2°
20M450	4500	1563	2235	2000	4°/-2°
20M500	5000	1730	2400	2000	4°/-2°
20M550	5500	1897	2568	2000	4°/-2°
20M600	6000	2063	2735	2000	4°/-2°
20M650	6500	2230	2900	1900	4°/-2°
20M700	7000	2397	3068	1800	4°/-2°
20M750	7500	2563	3234	1600	4°/-2°
20M800	8000	2730	3400	1400	4°/-2°
20M850	8500	2897	3567	1200	4°/-2°
20M900	9000	3063	3734	1000	4°/-2°
20M950	9500	3230	3900	800	4°/-2°
20M1000	10000	3397	4067	900	4°/-2°
20M1050	10500	3563	4234	800	4°/-2°
20M1100	11000	3730	4400	700	4°/-2°
20M1150	11500	3897	4567	600	4°/-2°
20M1200	12000	4063	4733	550	4°/-2°
20M1250	12500	4230	4900	500	4°/-2°

Types CLG2R020 -SM/N			
Door frame	9500mm		
h3 (mm)	Q (kg)		
9500	800	600	400
9000	1000	700	600
8500	1200	900	800
8000	1400	1100	1000
7500	1600	1300	1200
7000	1200	1500	1400
6300	2000	1700	1600
C (mm)	600	700	800

Types CLG2R016-SM/N			
Door frame	9500mm		
h3 (mm)	Q (kg)		
9500	600	400	200
9000	800	500	300
8500	900	600	400
8000	1000	750	500
7500	1200	950	700
7000	1400	1150	900
6300	1600	1300	1100
C (mm)	600	700	800

